

REVISIONS			
REV	DESCRIPTION	DATE	APPROVED

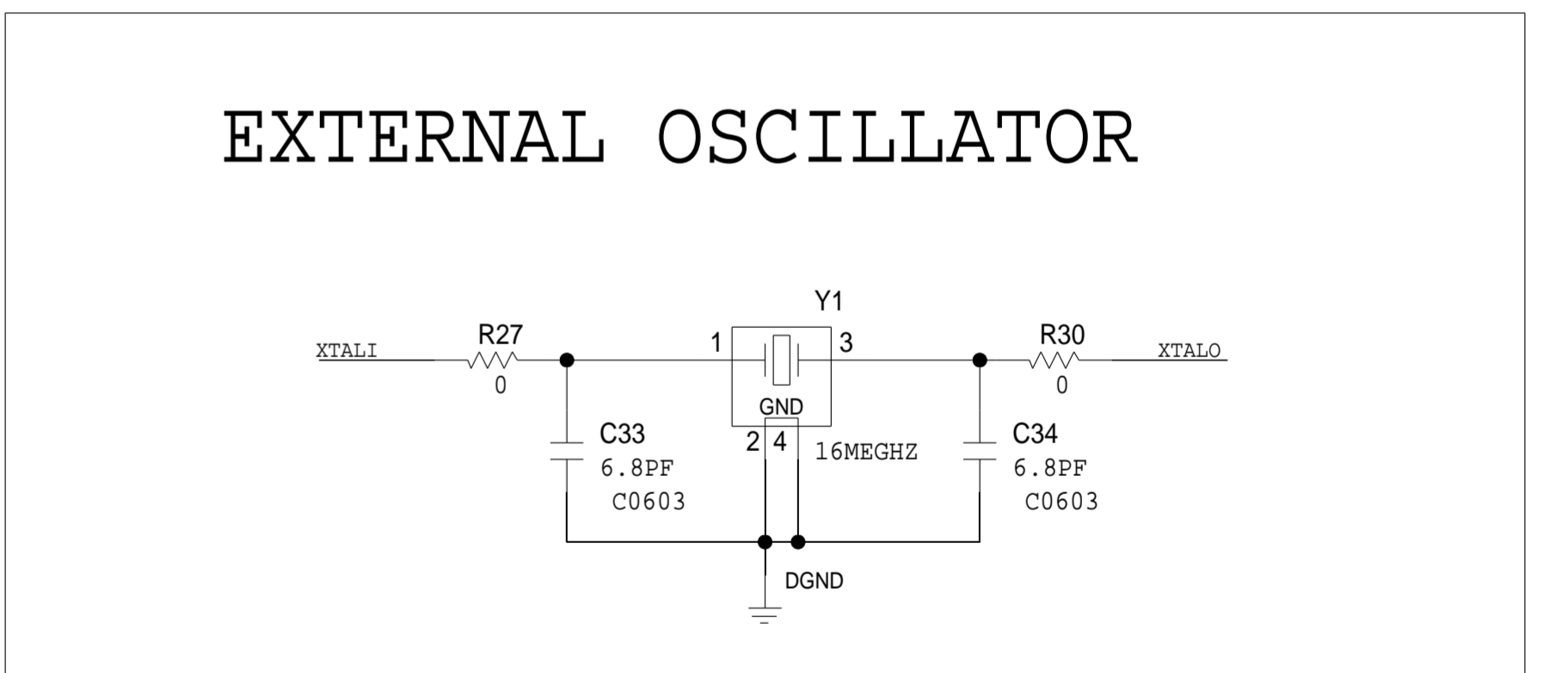
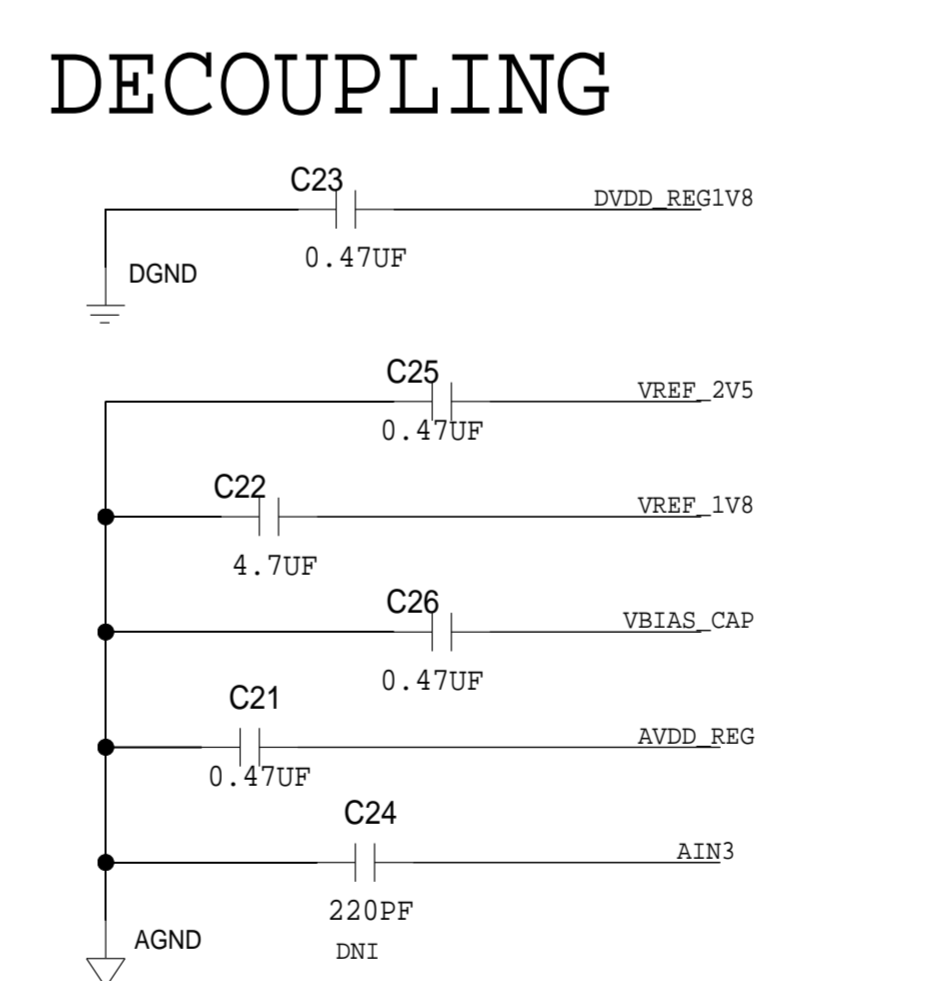
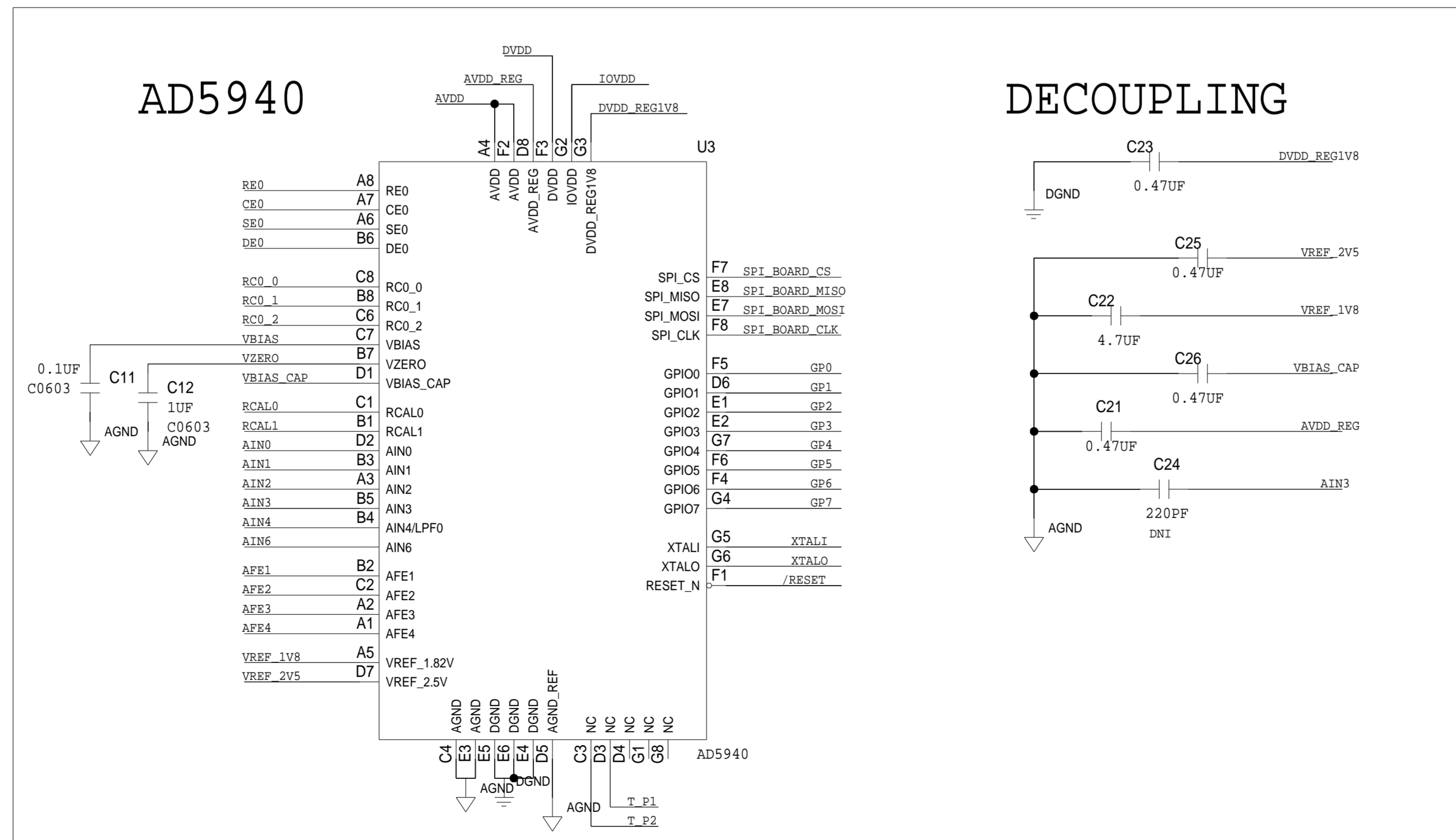
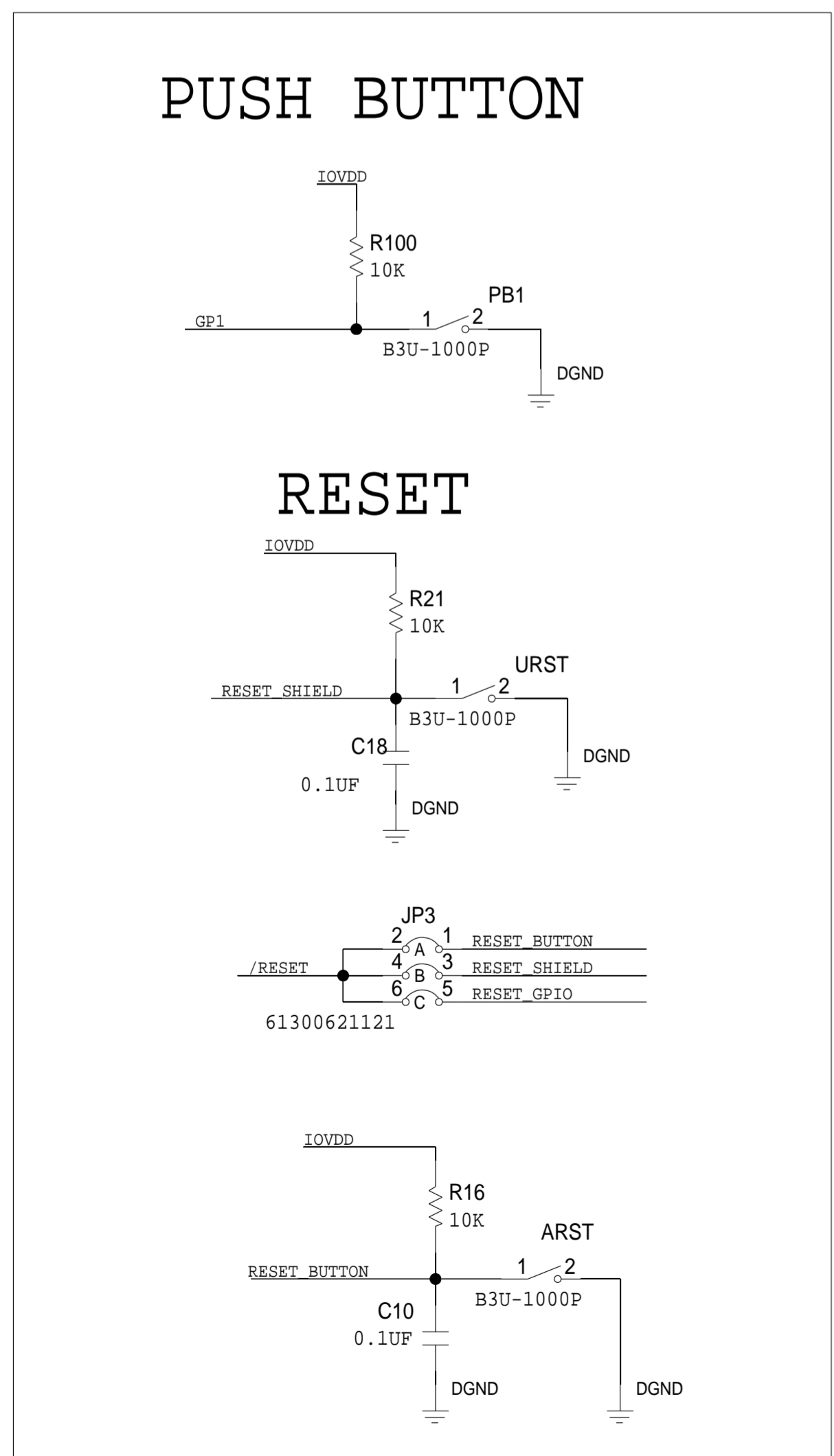
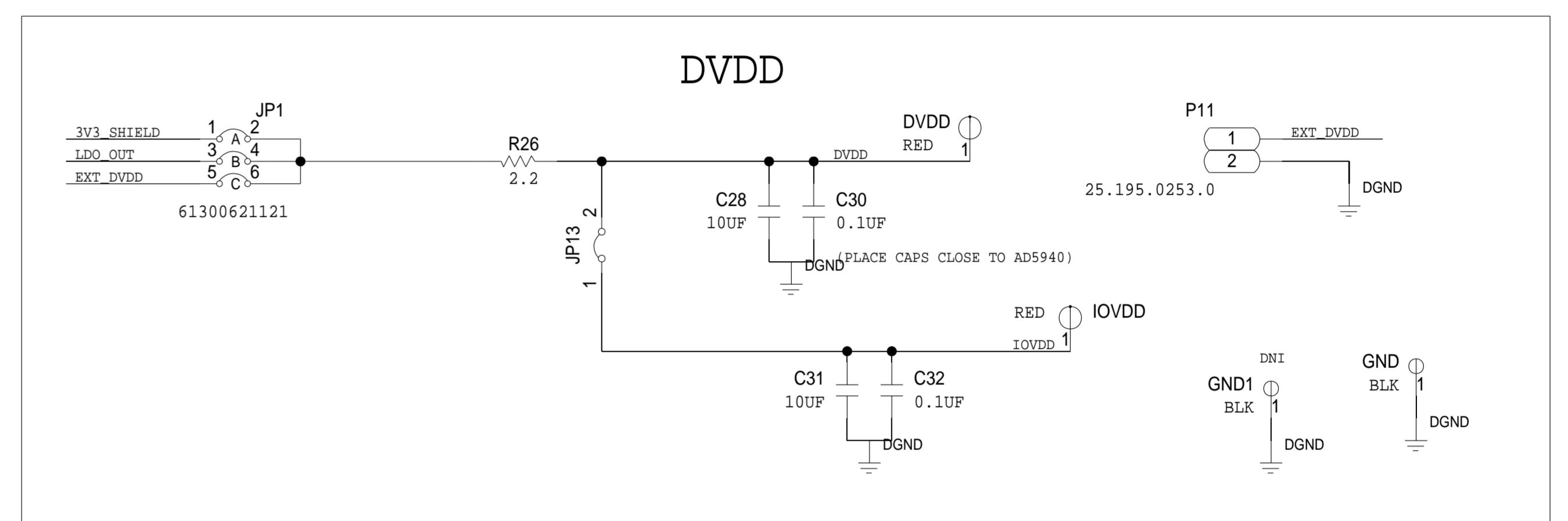
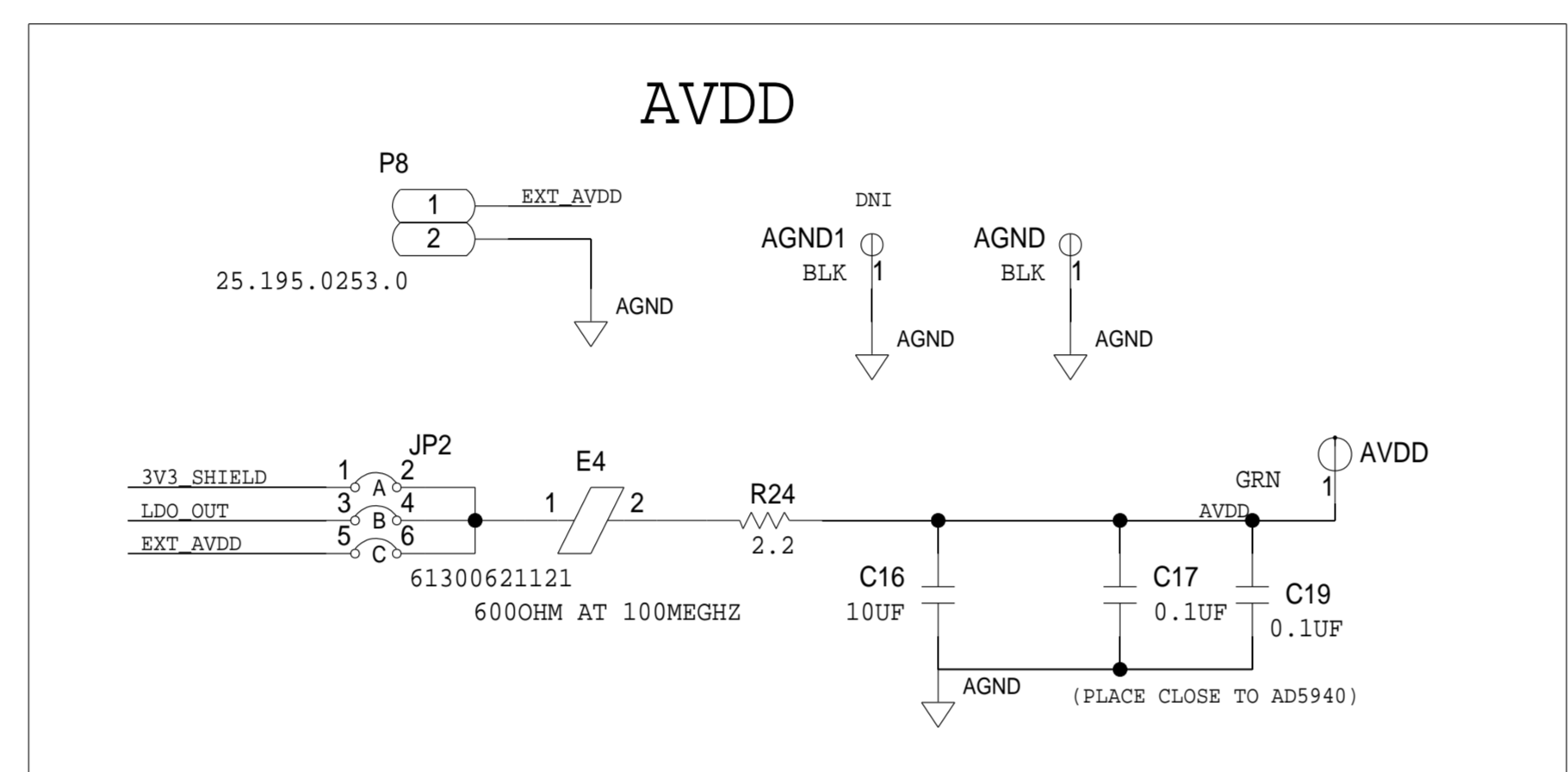
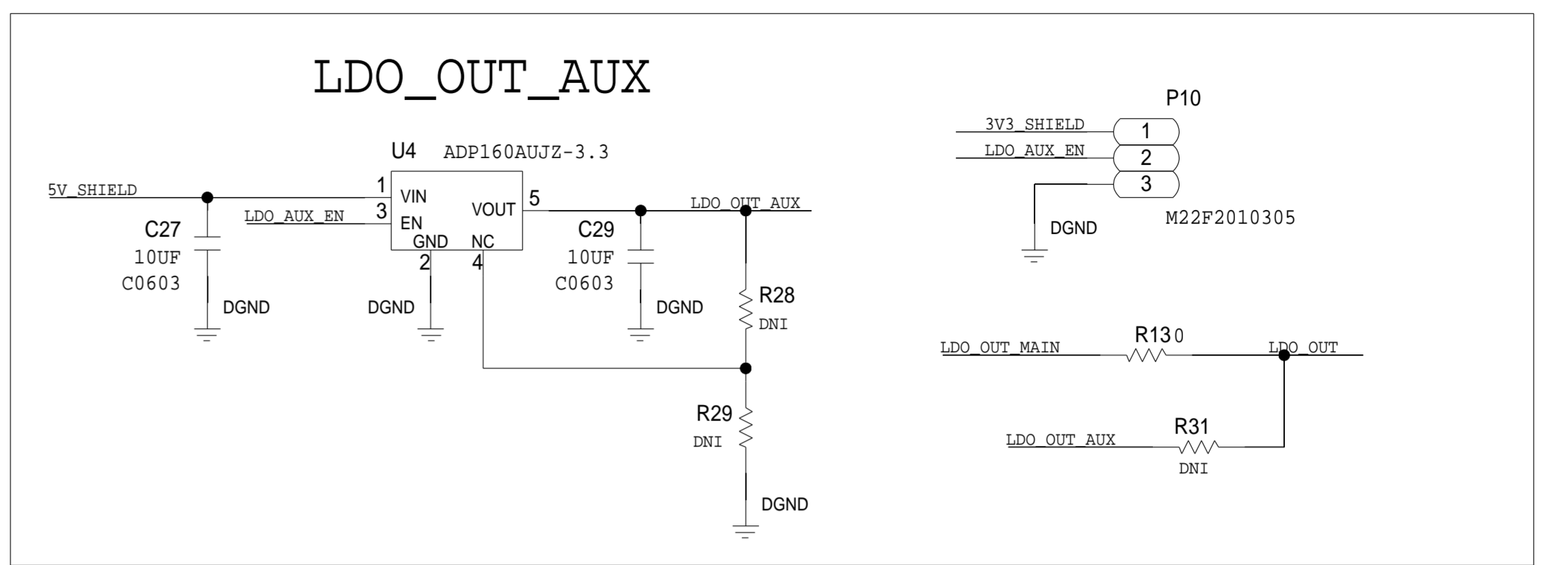
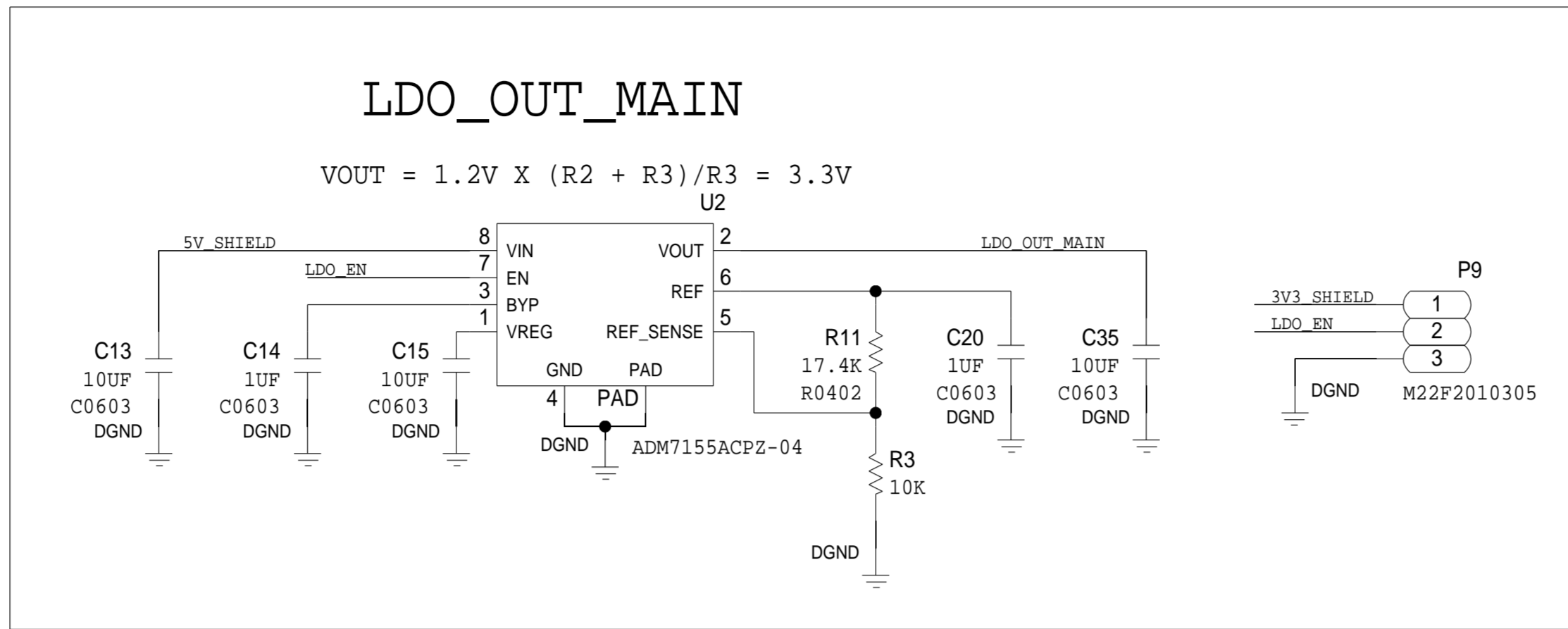
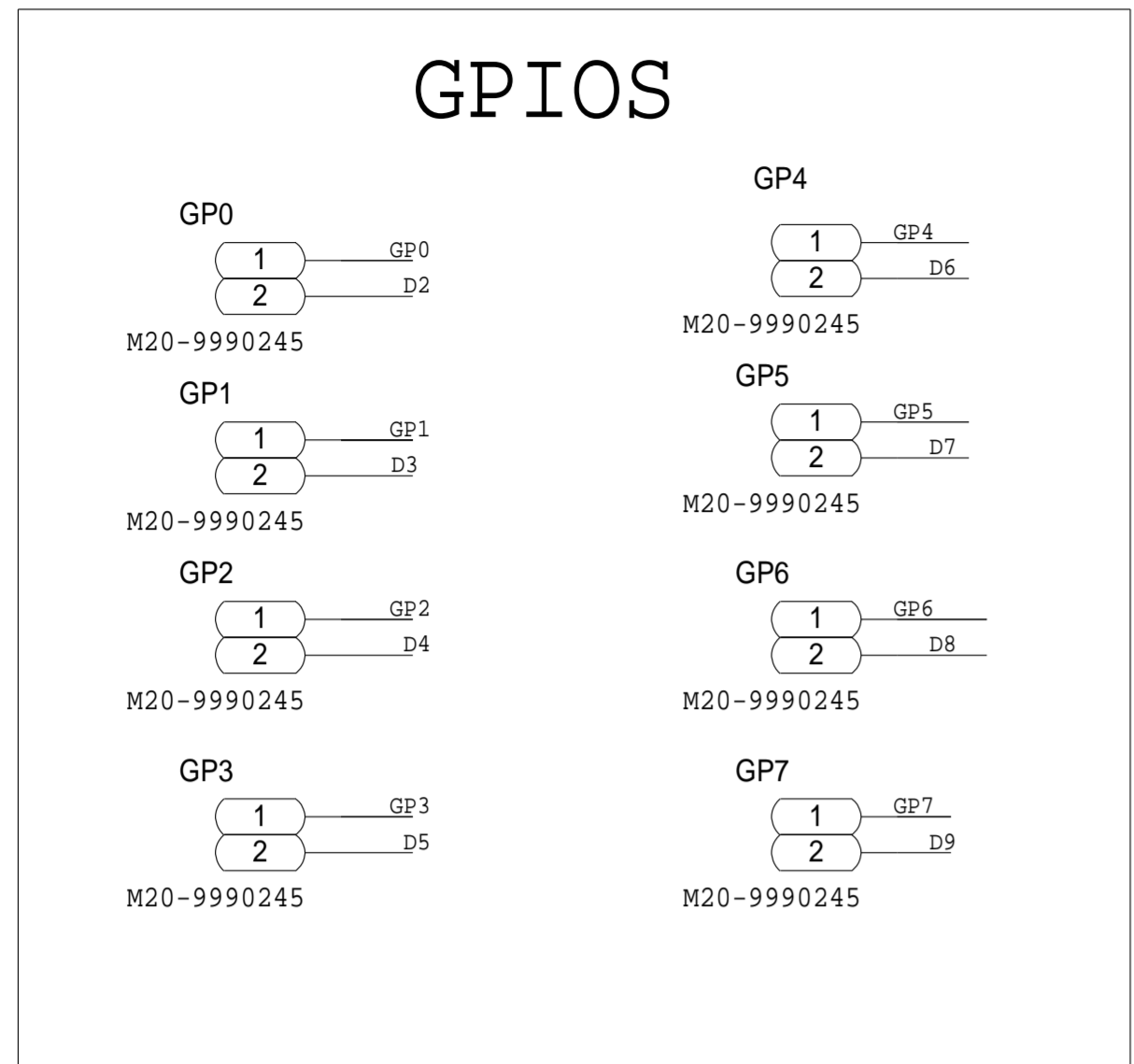

	SCHEMATIC		
	HW TYPE : Customer Evaluation Z Product(s) : AD5940ELCZ : N/A		
DESIGN VIEW <DESIGN_VIEW>	DRAWING NO. 02_050193	REV A	
PTD ENGINEER M LAMBE	SIZE D	SCALE 1:1	SHEET 2 OF 3

REVISIONS			
REV	DESCRIPTION	DATE	APPROVED

ARDUINO CONNECTION

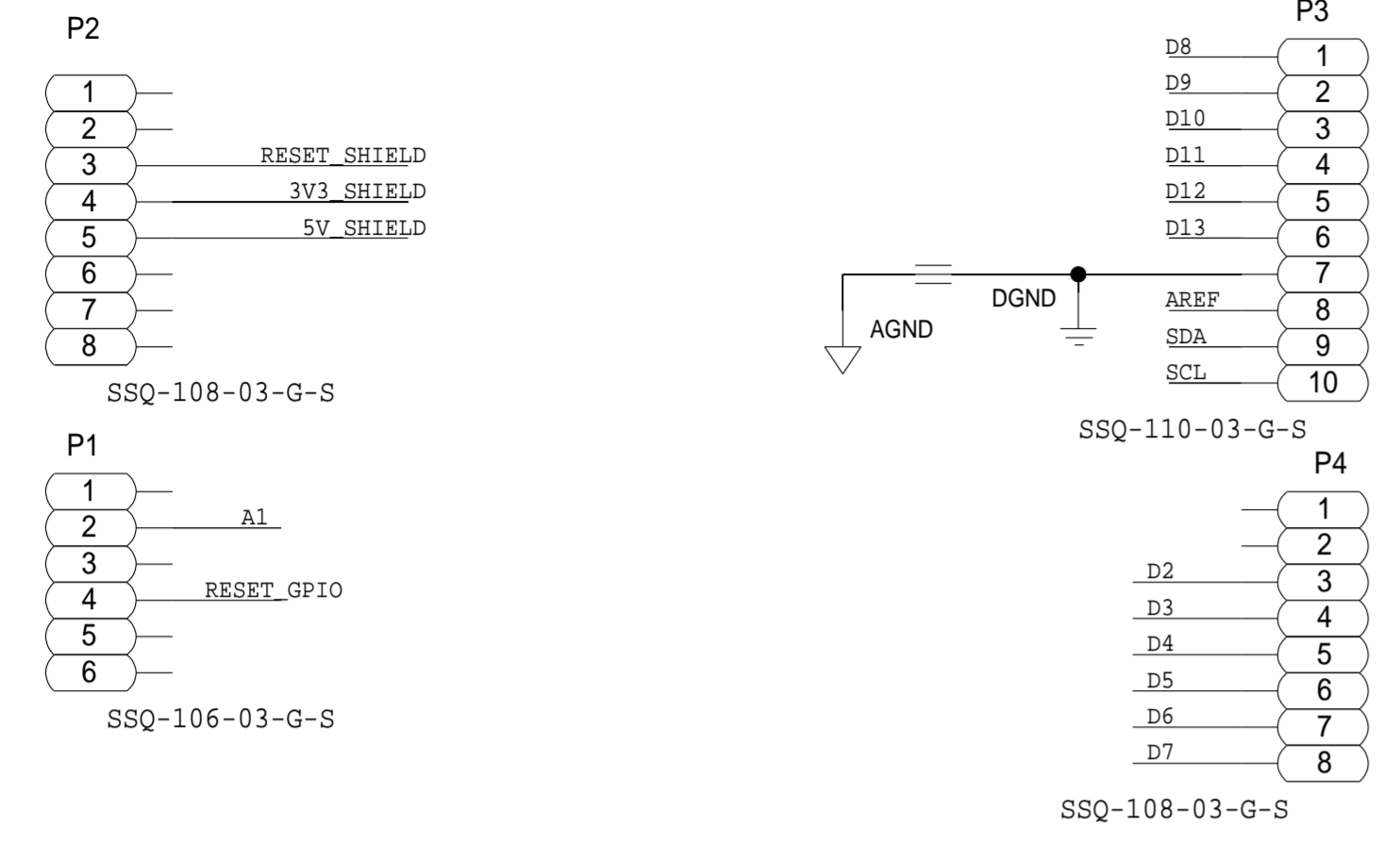

MICRO USB

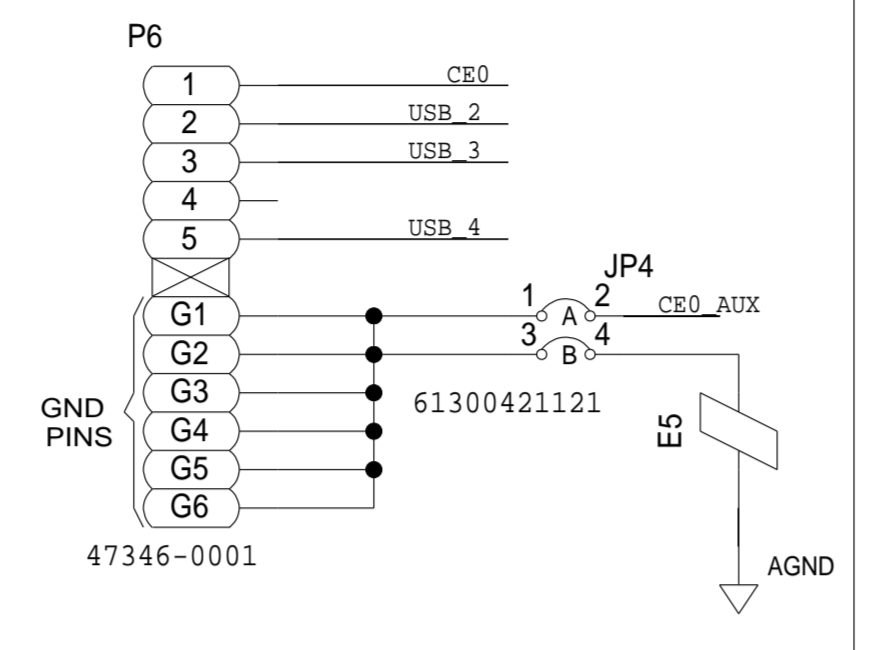

EXT DISCRETES

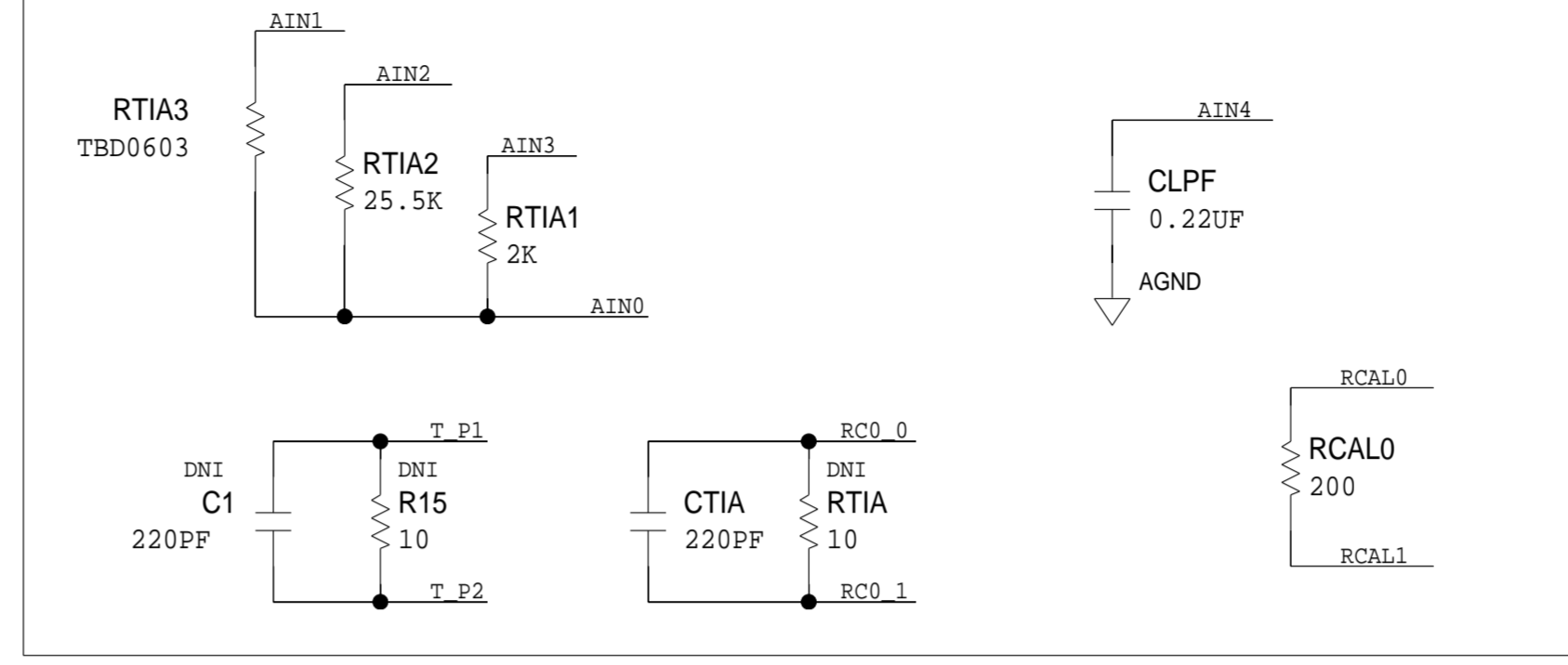

EC SENSOR CHANNEL 0

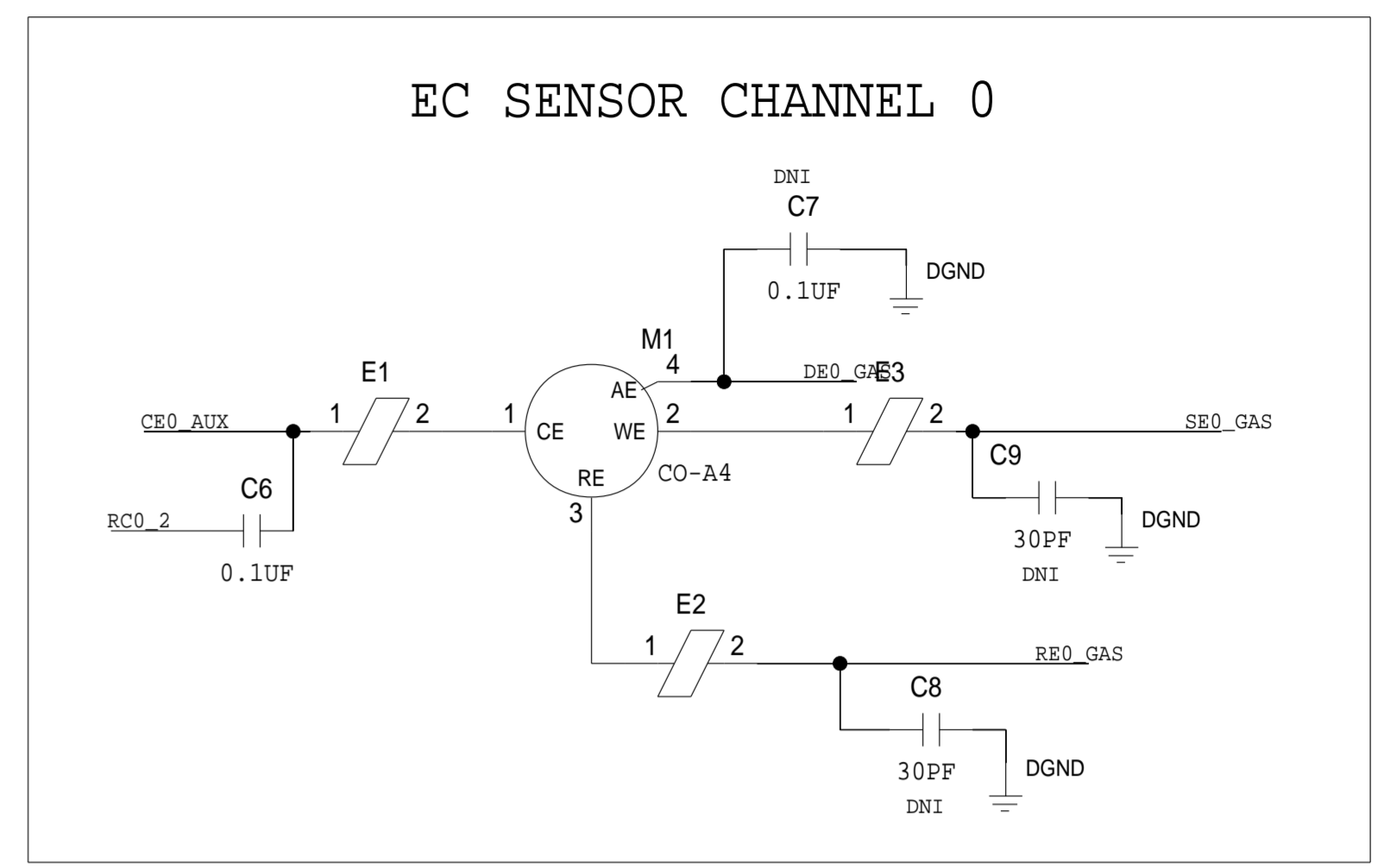

HIGH Z CHANNEL

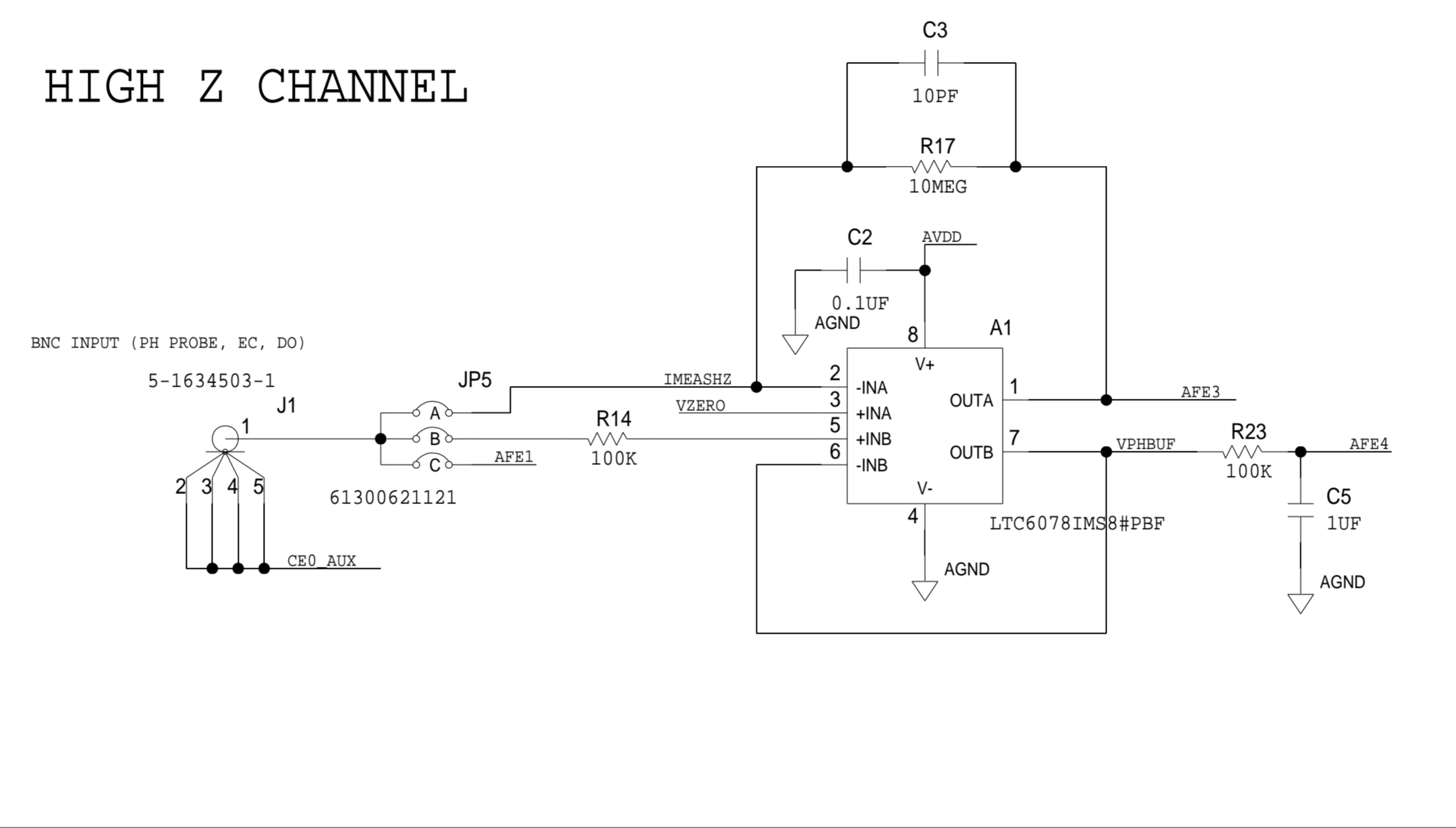

SIGNAL MUX JMPRS

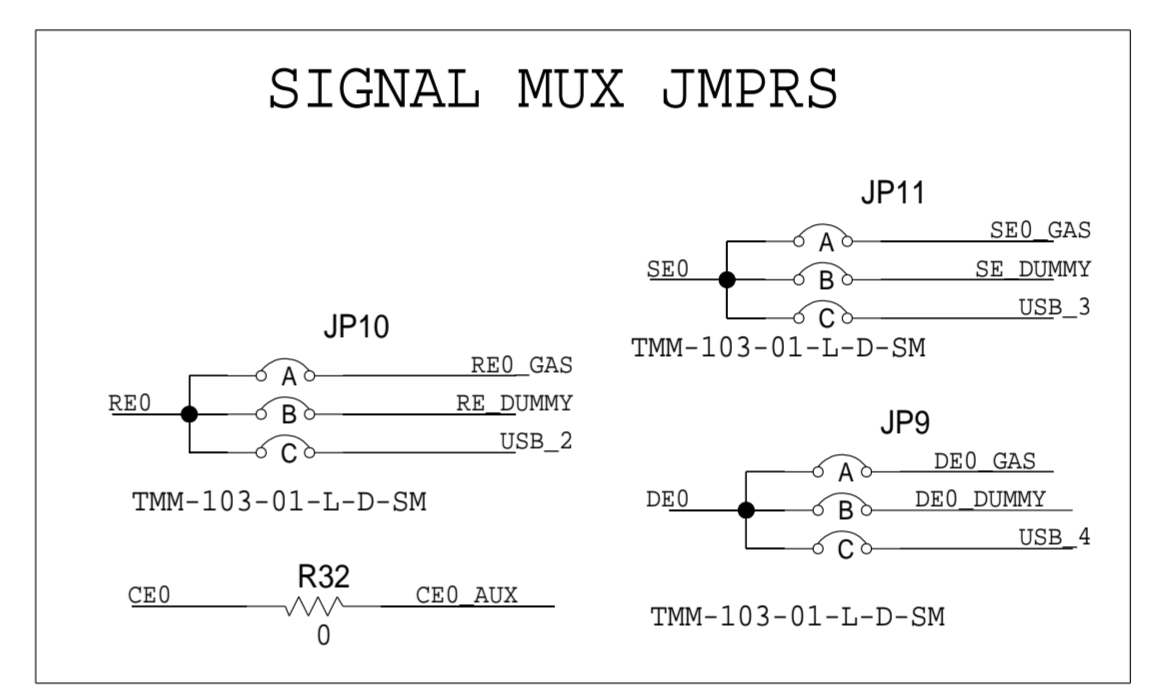

I2C MEMORY

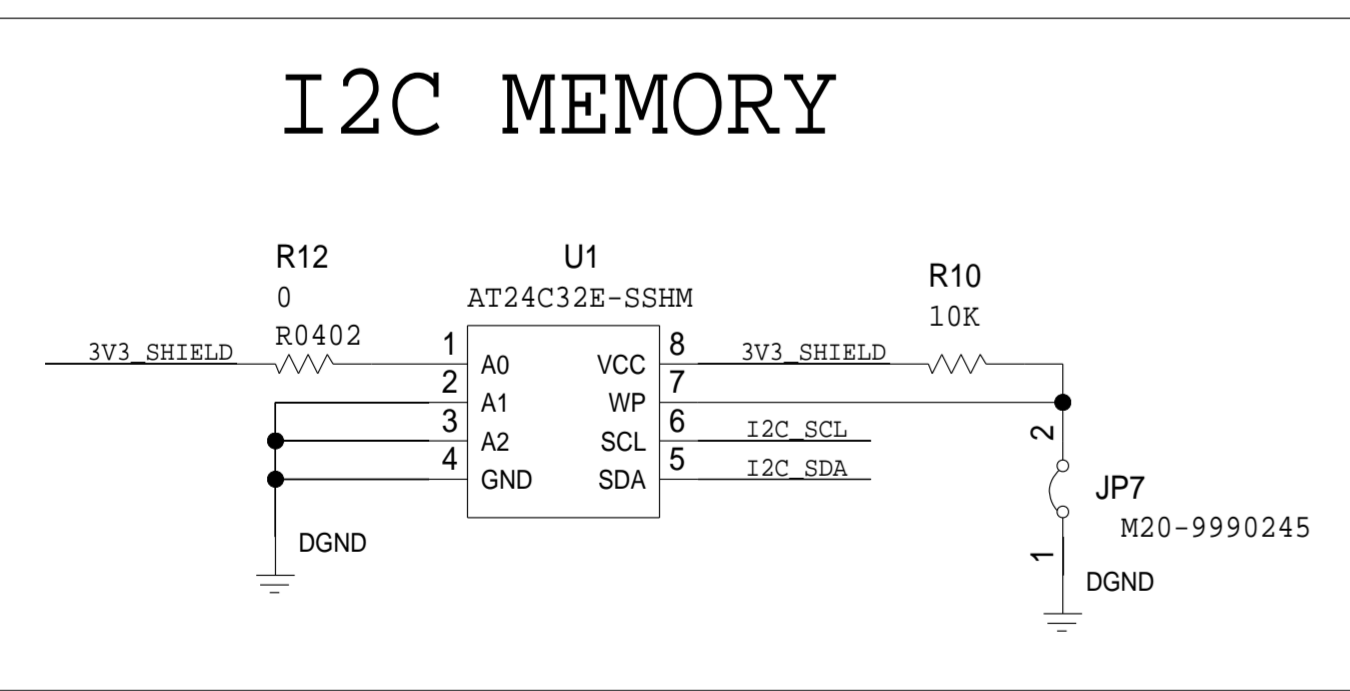

LEDS

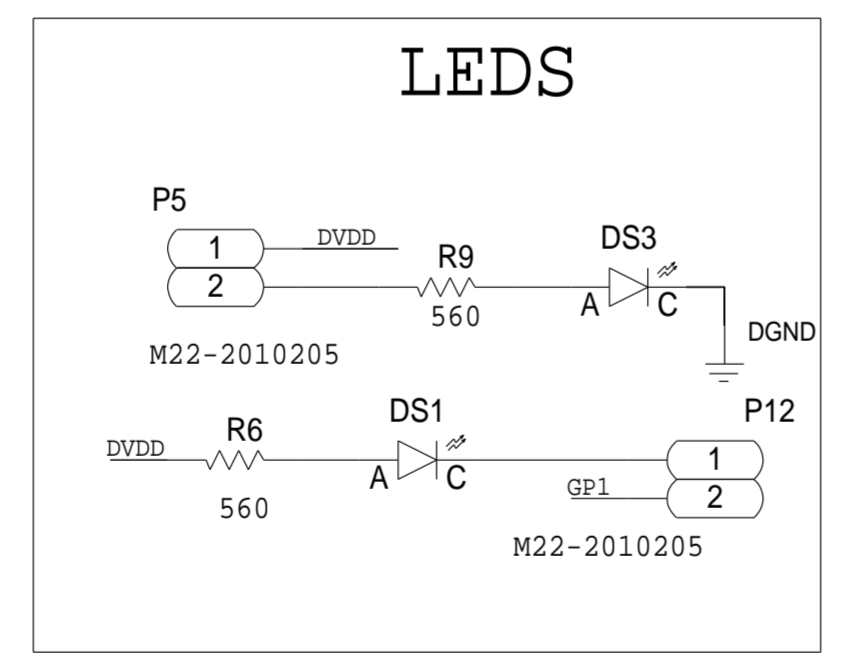

ANALOG SIGNALS

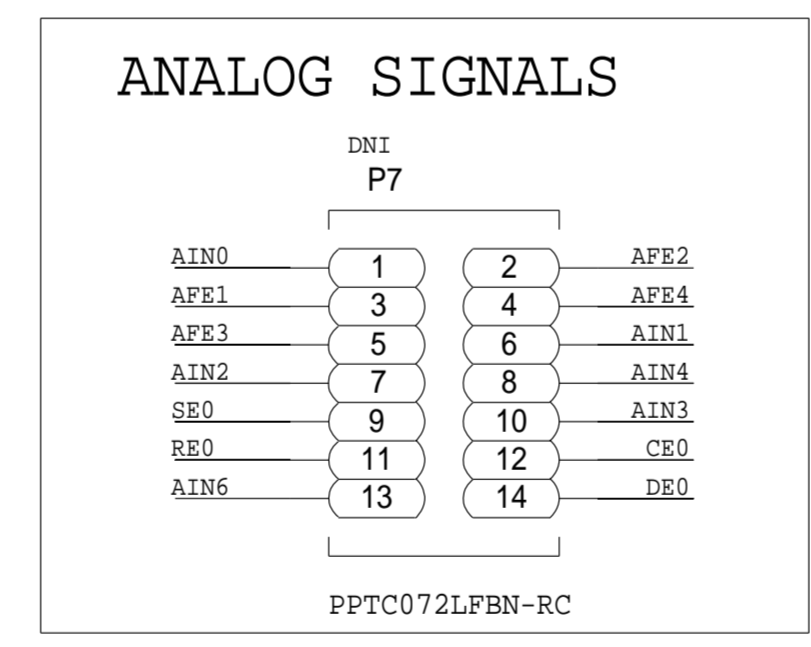

DUMMY SENSORS

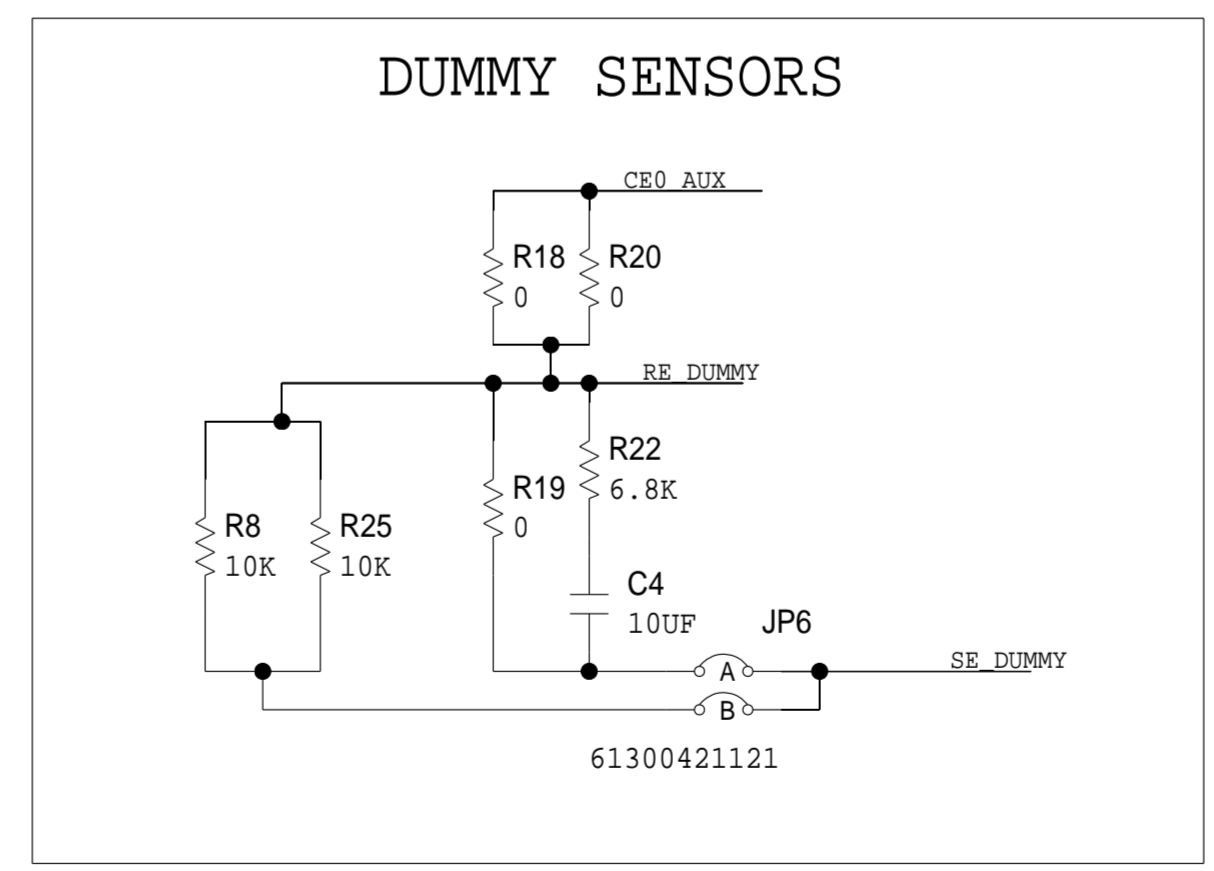

	SCHEMATIC		
	HW TYPE : Customer Evaluation Z Product(s) : AD5940ELCZ : N/A		
	DESIGN VIEW <DESIGN_VIEW>	DRAWING NO. 02_050193	REV A
	PTD ENGINEER M LAMBE	SIZE D	SCALE 1:1
		SHEET 3 OF 3	